



M-FORCE[®]

WIDE BLADE ASSEMBLY INSTRUCTIONS



1 Remove Cutter Assembly for cleaning by sliding with your fingers to separate lower blade.

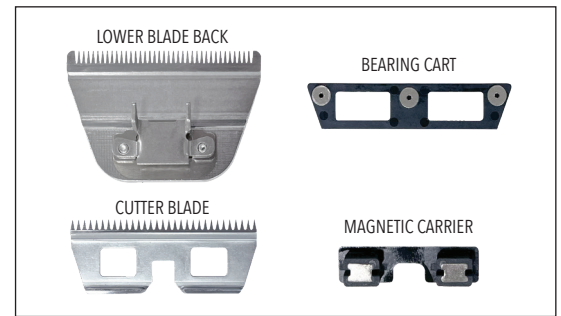

2 Separate all assembly parts.



3 Once separated, brush or blow away any hair before reassembly. All existing cleaners, air canisters, etc. can be used with M-Force[®] blades.



4 Attach Magnet Carrier to top of the Cutter, not in the cutter channel.



5 Place Bearing Cart back on assembly. Bearing Cart sides should match the same angle as the cutter angle and magnets should be by teeth of the cutter. You see 5 magnets - 3 circles & 2 rectangles as shown.



6 Slide assembly back into channel of the Lower Blade.

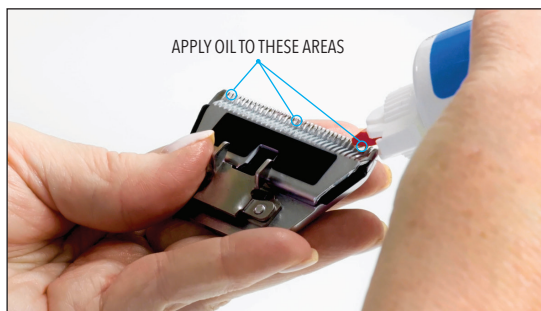

7 Apply oil to these three places on the blade. Wipe off any excess oil.



8 Reinstall on any Detachable Blade Clippers and begin use.

VIEW VIDEO
OF ASSEMBLY
INSTRUCTIONS

